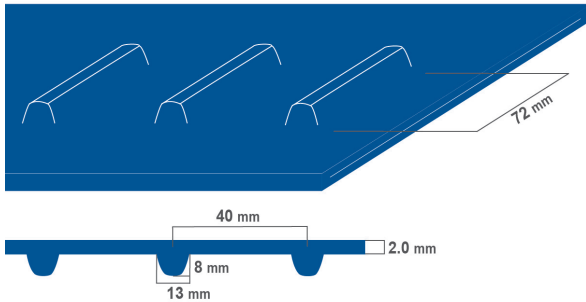

**CODE** NA1729C\_D13

**TYPE**
**HP Compact Drive 20/40 blue AM**
**COMPOSITION**

**PRODUCT SYSTEM**

Description	Compact belt with traction core treated to avoid waving, timing profile on the drive side	
Material	Polyurethane (TPU) - HP® system	
Thickness	2.00 mm	0.08 in.
Weight	2.10 kg/m <sup>2</sup> + 0.18 kg/m (for row of teeth) 0.43 lbs./sq.ft + 0.12 lbs./ft (for row of teeth)	
Surface pattern	Smooth	
Colour	HP® blue	
Coefficient of friction	MF	

**TECHNICAL SPECIFICATIONS**

Elongation at 1%	8 N/mm	46 lbs./in.
Pitch	40 ± 0.4 mm	1.57 ± 0.16 in.
Temperature resistance <sup>(2)</sup>	min. -30 °C	-22 °F
	max. +90 °C	194 °F
<sup>(1)</sup> Use of the belt with limit values may reduce its life		
Max. production width	2000 mm	79 in.
Minimum roller diameter:		
■ Bending roller	mm	in.
■ Counter-bending roller	120 mm	4.7 in.
Coefficient of friction:		
■ Stainless steel - dry/wet	0.50/0.42 [-]	
■ UHMW <sup>(2)</sup> - dry/wet	0.42/0.35 [-]	

<sup>(2)</sup>UHMW = Ultra High Molecular Weight

**FEATURES**

Humidity influence	no
Suitable to metal detector	yes
Permanent antistatic dynamically (UNI EN ISO 21179)	no
Static conductivity (UNI EN ISO 284)	no
C.I.P. (Clean In Place)	yes
Conveying on plastic strips UHMW <sup>(2)</sup>	yes
Conveying on rollers	yes
Troughed conveying	yes
Swan neck conveying	no
Inclined conveying	no
Accumulators belts	no
Curved conveyor	yes
Chemical resistances <a href="#">link</a>	12

**COMPLIANCE**

REACH EC 1907/2006 Regulation and Amendments  
 EC 1935/2004 Regulation and Amendments  
 EC 2023/2006 Regulation and Amendments  
 EU 10/2011, 2023/1442 Regulation and Amendments  
 HACCP (Hazard Analysis and Critical Control Points)  
 FDA (Food and Drug Administration)

**SUITABLE FOR**

Food: meat and fish processing  
 Food: seafood processing  
 Food: cheese processing  
 Fruits and vegetables  
 Food: bakery  
 Food: sweet and salty snacks

**NOTES**

Issue: 20-04-2023

Last Update: 20-04-2023

**DISCLAIMER**

The information contained in this document describes the features of the CHIORINO product as tested in a laboratory environment at a temperature of +23 degrees °C at 50% relative humidity. It does not necessarily reflect the conditions of industrial use and it does not guarantee the product to be suitable for certain applications. The client remains liable for the proper selection and correct use of the CHIORINO product. CHIORINO cannot be held responsible should damages arise from the use of its products. Necessary alterations to this data can be made without prior notice.